

LCD Display Manual



1. Basic information

- 3.2 inch color TFT screen
- 48V/60V/72V power supply
- Normal operating temperature of the instrument -20~65° C
- The instrument case is ABS, black, transparent lens is ordinary acrylic, high hardness, with protective film



- Size:

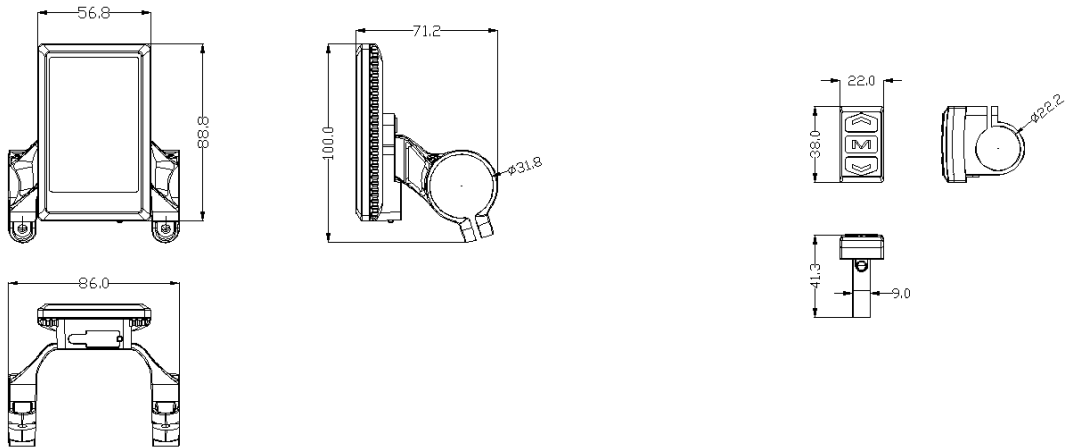

2. LCD display instructions

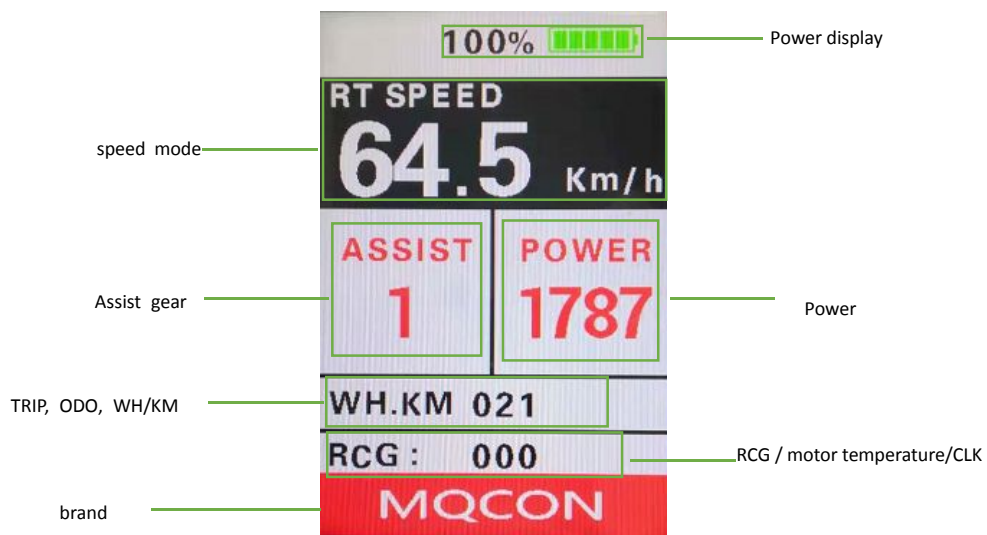

- Battery display: 5 segments of power indication, the customer can select the percentage display and the display of the actual voltage value
- Speed mode: real-time speed RT SPEED, maximum speed MAX SPEED, average speed AVG SPEED;

- Power display: power real-time display
- Speed display: unit Km / h km per hour, MPH miles per hour;
- Assist gear position: according to the pas mode, 0~9 files can be displayed.
- Motor temperature: monitor motor temperature in real time;
- Mileage mode: cumulative mileage ODO, single mileage Trip,
- WH.KM: the controller power consumption ,wh/km
- RCG: controller cumulative charge Ah to battery while in regen mode .
- Clock: Built-in battery, user set the year, month, day, hour, minute and second.

3. Key Function

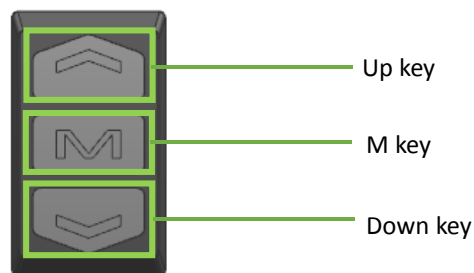

- **Switch function:**
Press and hold the M button for about 2 seconds to turn it on and off.
- **Day/Night Mode Switch:**

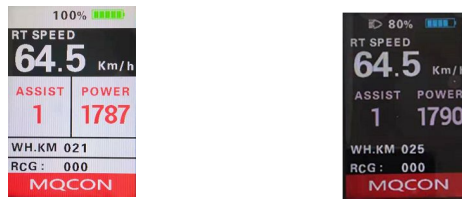

In the main interface, long press “Up” to enter the switch day/night mode, the LCD tone will be adjusted to night mode, and the headlights will be turned on automatically.

➤ **gear position set:**

In the main interface, short press “Up” and “Down” to switch gears.

➤ **Speed mode switching**

In the main interface, first press the “M key” to enter the speed display mode switch, then press the “Up” or “Down” button to switch the display in turn: real-time speed (RT), maximum speed (MAX), average Speed (AVG).。

➤ **Mileage mode / WH.KM switching**

Press “M” again can enter the ODO/Trip/WH.KM switching mode, which displays: total mileage, single mileage,controller consumption

➤ **TEMP/ RCG/ CLK switching**

Press “M” again can enter the TEMP/RCG/CLK switching mode,which display: motor temperature, regen Ah, clock

4 . Parameter setting

1). Press and hold the “Up” key + “Down” at the same time to enter/exit the setting parameters.

2). In the setting interface, the leftmost red cursor arrow is used to indicate the position of the currently set parameter.

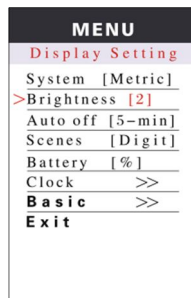

3). Short press the M key, the setting parameter value on the right side of the current line turns red, enter the parameter modification mode, short press the up and down keys to change the setting parameters, press the M key again, exit the current parameter modification mode, enter the parameter switching/selection mode, short Press the up/down keys to move the current setting parameters up and down.

4). At the bottom of the setup parameters, there are EXIT, Basic (other pages have Display, etc.). Under this parameter, short press M to enter/exit the lower level or current level menu.

Display setting interface	
Item	Description
System	Setting the metric and imperial effects speed display and does not affect the "wheel" settings in Basic setting menu.
Brightness	Backlight brightness setting
Auto off	Automatic sleep time, off is not automatic sleep
Battery	Main interface, battery display mode, voltage mode and battery compartment
clock	Set the time of the clock, such as year, month, day, hour, minute, and second
Basis	Basic settings, submenu entry

Basic setting interface	
Item	Description
wheel	Motor tire diameter, fixed in inches, independent of other "system" settings
battery	Select according to the battery voltage currently used
start password	This menu can't be entered or the button is invalid.
advance	Advanced settings, submenu entry
factory	Restore factory settings parameters

Advance setting interface	
Item	Description
assist level	PAS mode speed split: There are 3, 5 and 9 modes; please select 5 mode
speed limit	the controller use the computer or app settings instead of the LCD settings.
current limit	
power limit	
poles in motor	Enter the number of magnetic steel sheets. For example, 23 poles motor, enter 46 here.
magnet disk	PAS Speed magnets, the controller ignores the LCD settings
start mode	zero start: the throttle can drive the motor at the zero speed of the motor; non-zero start: Only when the motor speed is not 0, the throttle can drive the motor
drive mode	0: only PAS is valid 1: only the throttle is valid; 2: pas and throttle are valid
start sensor	after a few laps (set value), the PAS begins to function.
start strength	controller currently ignore meter settings
throttle level	controller currently ignore meter settings
clockwise	controller currently ignore meter settings
throttle 6km	controller currently ignore meter settings
key antijam	controller currently ignore meter settings
assist forward	controller currently ignore meter settings

remark: Due to the upgrade of the company's products, the display content of the product you get may be different from the manual, but it will not affect your normal use.